

DiskOnModule

Hi-Speed DQ Series



TABLE OF CONTENTS

1. PRODUCT DESCRIPTION	1
1.1 PRODUCT OVERVIEW	1
1.2 PRODUCT FEATURES	1
1.3 SYSTEM REQUIREMENT	1
1.3.1 <i>Power Requirement</i>	1
1.3.2 <i>Operating System</i>	1
1.3.3 <i>Interface</i>	1
2. SPECIFICATION	2
2.1 PHYSICAL SPECIFICATIONS	2
2.1.1 <i>Overlook</i>	2
2.1.2 <i>Dimension</i>	3
2.1.3 <i>Weight</i>	3
2.2 ELECTRONIC SPECIFICATIONS	4
2.2.1 <i>Product Definition</i>	4
2.2.2 <i>Operating Voltage</i>	4
2.2.3 <i>Capacity and Block Size information</i>	4
2.2.4 <i>Power Consumption</i>	4
2.3 PERFORMANCE SPECIFICATIONS	5
2.3.1 <i>Modes</i>	5
2.3.2 <i>Seek Time</i>	5
2.3.3 <i>Mount Time</i>	5
2.3.4 <i>Data Transfer Time</i>	5
2.3.5 <i>Data Retention</i>	5
2.3.6 <i>Wear-leveling</i>	5
2.3.7 <i>Bad Block Management</i>	5
2.4 ENVIRONMENTAL SPECIFICATIONS	5
2.4.1 <i>Temperature</i>	5
2.4.2 <i>Humidity</i>	5
2.4.3 <i>Vibration</i>	5
2.4.4 <i>Bare Drop Testing</i>	5
2.4.5 <i>Shock and Altitude</i>	6
2.5 RELIABILITY SPECIFICATIONS	6
2.5.1 <i>ECC/EDC (Error Correction Code/Error Detection Code)</i>	6
2.5.2 <i>Read and Write/Erase Cycle</i>	6
2.5.3 <i>MTBF (Mean Time Between Failure)</i>	6
2.6 COMPLIANCE SPECIFICATIONS	6
3. FUNCTION	7

3.1 SWITCH SETTING	7
3.2 PIN SIGNAL ASSIGNMENT	7
3.3 CAPACITY SPECIFICATIONS	8
3.4 ABSOLUTE MAXIMUM RATINGS	8
4. ORDERING INFORMATION	8

LIST OF FIGURES

Figure 1: DiskOnModule Overlook Diagram 2
Figure 2: DOM Dimensions 3
Figure 3: DiskOnModule Block Diagram 4
Figure 4: Master/Slave Function Switch 7
Figure 5: Signal Connector 8

LIST OF TABLES

Table 1: DiskOnModule Physical Dimension 3
Table 2: ATA connector pin definitions 7
Table 3: Capacity Specifications 8
Table 4: Absolute Maximum Rating 8
Table 5: DiskOnModule Ordering Information 8

1. Product Description

1.1 Product Overview

PQI's DiskOnModule (DOM) is the storage device based on NAND flash memory technology. This product complies with 44 PIN IDE (ATA) standard interface and is suitable for data storage media and code storage device for embedded system and boot disk. By using **DiskOnModule**, it is possible to operate good performance for the systems, which have IDE interface.

With small form factor, the applicable appliance can add or install IDE storage device on its Mother Board or Complete set.

● Application Fields;

- Industrial PC and Thin Client
- Game and Telecommunication Machine
- Ticketing, Examining, testing machine
- Army, Health and Production Equipment and Machine

1.2 Product Features

- Small form factor with IDE (ATA) Standard Interface connector
- Memory Capacities: 32MB ~ 4GB
- High performance and reliability
- Noiseless and stable installation to system
- Operating voltage 3.3V or 5.0V operation
- Standard IDE (ATA) Interface
- Master and Slave Switch
- Operating as Boot Disk
- Data Storage Device to 4GB
- Code Storage Device for Embedded Operating System

1.3 System Requirement

- The Host system which is connected to DiskOnModule should meet system requirements at minimum;

1.3.1 Power Requirement

- Voltage: DC +3.3V \pm 5% or DC +5.0V \pm 10%

1.3.2 Operating System

- Windows 2000/XP
- Linux
- DOS
- WinXP Embedded
- WinCE

1.3.3 Interface

- IDE (ATA) Standard Interface

2. Specification

2.1 Physical Specifications

2.1.1 Overlook

The overlook views of DiskOnModule are illustrated in Figure 1.

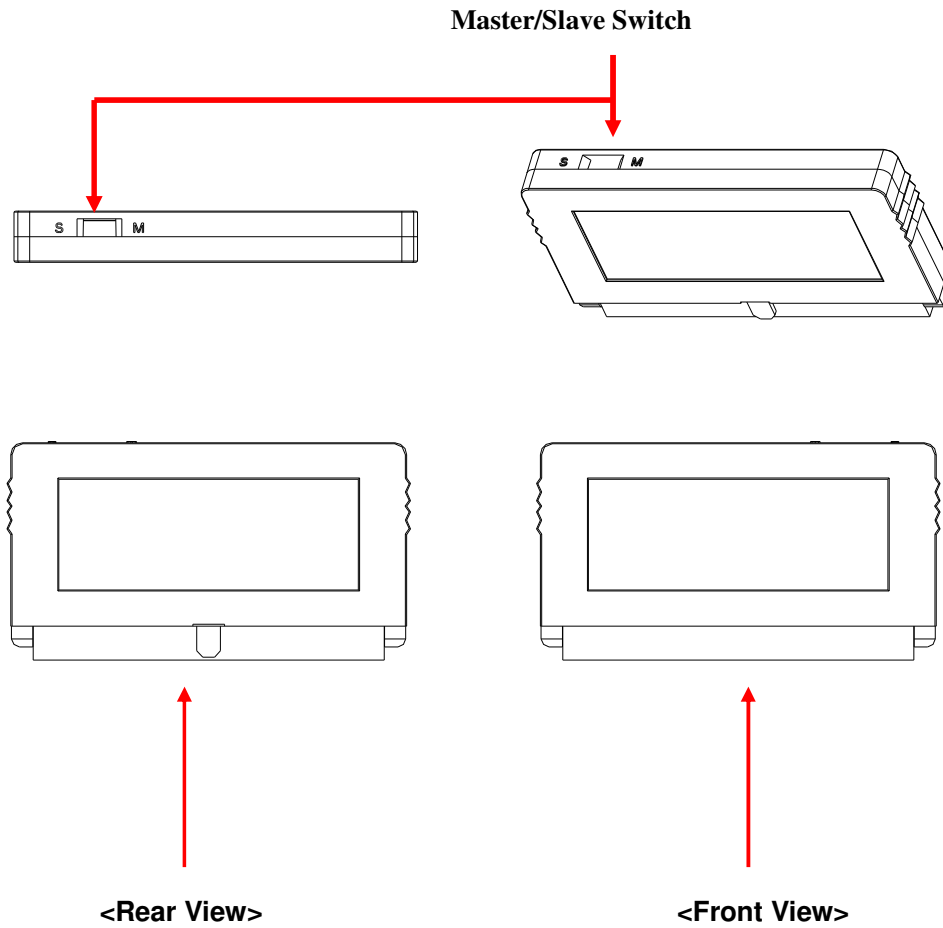

Figure 1: DiskOnModule Overlook Diagram

2.1.2 Dimension

The Dimensions of DiskOnModule are illustrated in Figure 2 by type.

DQ0XXX22XX0 (44 PIN)

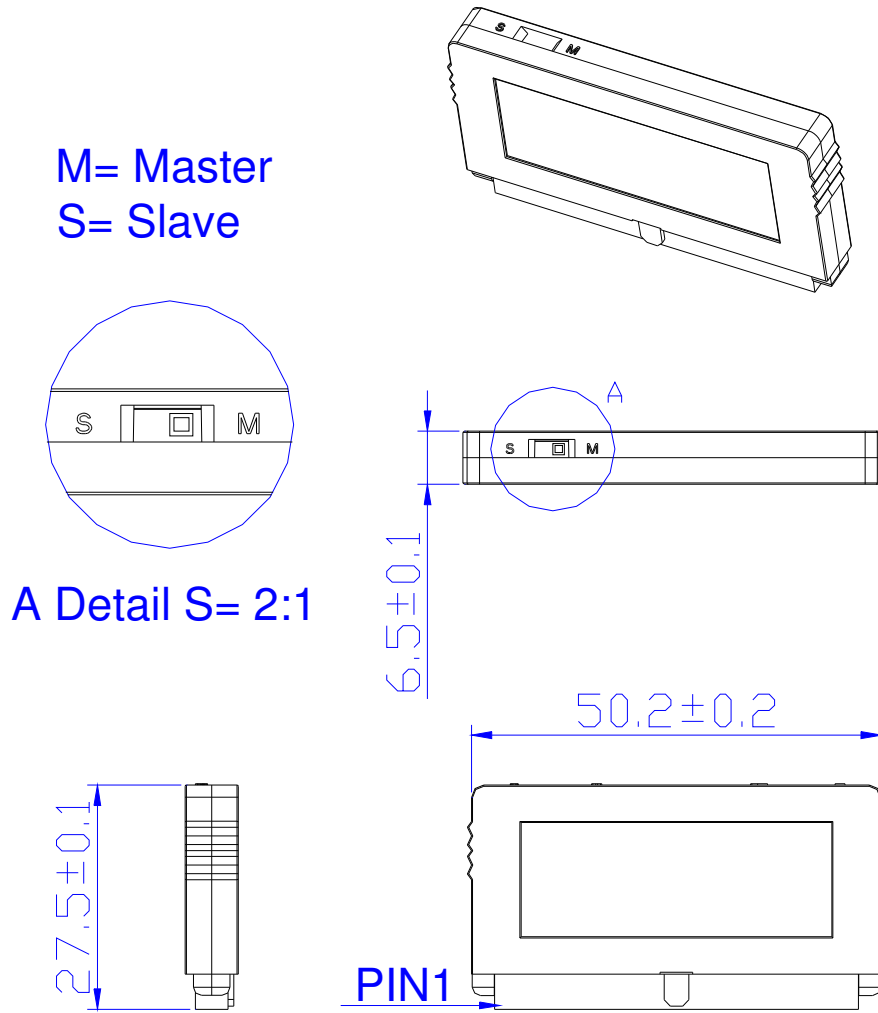

Figure 2: DOM Dimensions

Table 1: DiskOnModule Physical Dimension

Length	50.2 ± 0.2 mm
Width	27.5 ± 0.1 mm
Thickness	6.5 ± 0.1mm

2.1.3 Weight

- DiskOnModule Weight: < 12g

2.2 Electronic Specifications

2.2.1 Product Definition

DiskOnModule is designed to operate and work as Data or Code Storage device by NAND Flash Memory and its Controller through IDE (ATA) Standard Interface to Host Systems.

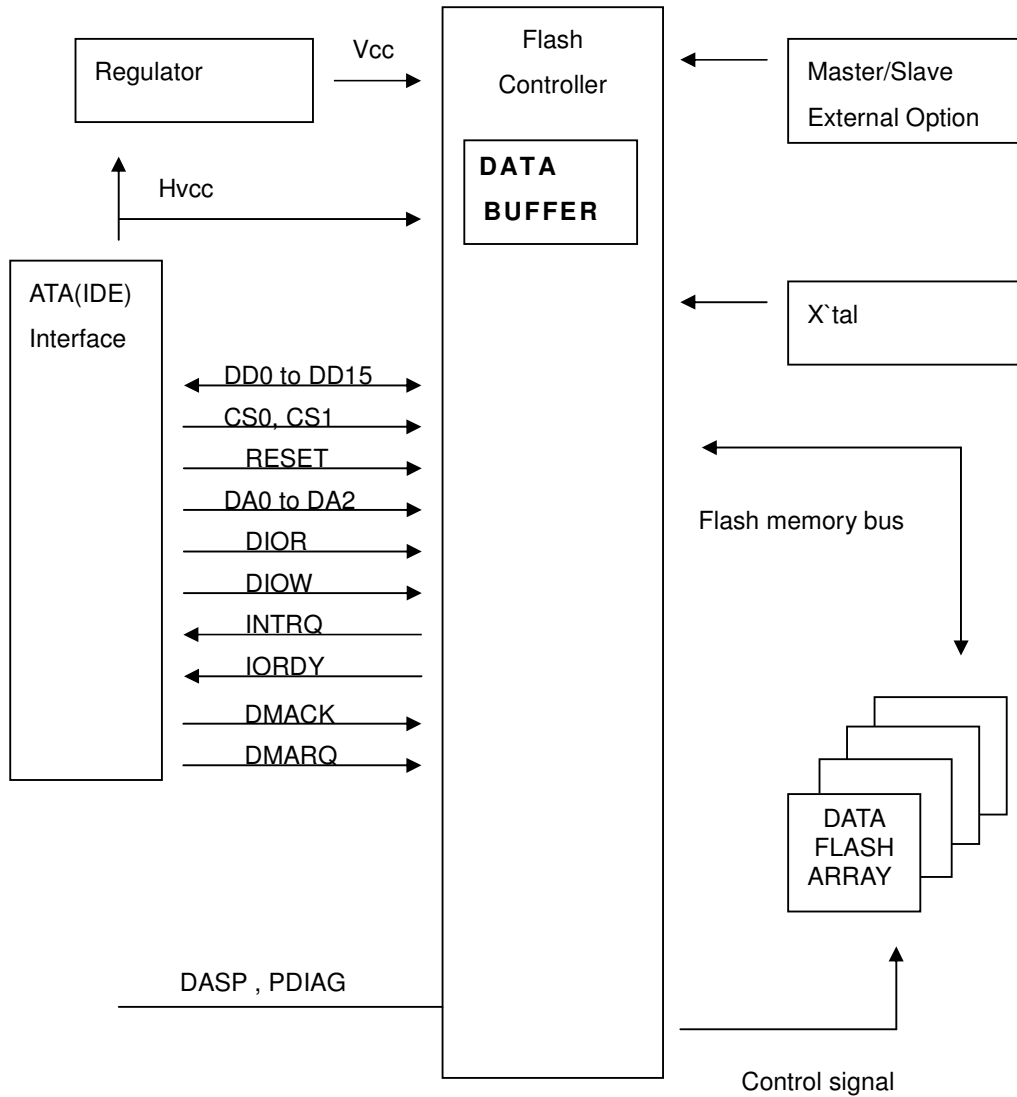

Figure 3: DiskOnModule Block Diagram

2.2.2 Operating Voltage

- Voltage DC +3.3V ± 5% (Option) or DC +5.0V ± 10%

2.2.3 Capacity and Block Size information

- Capacity: 32MB ~4GB
- Sector Size: 512B

2.2.4 Power Consumption

- DC Information
 - Read: <15mA (Typ.), Write: <20mA (Typ.), Sleep: <3mA (typ.)

Notice The value is various bases on the testing platform.

2.3 Performance Specifications

2.3.1 Modes

- Multi-Word DMA2
- PIO mode 4

2.3.2 Seek Time

- DiskOnModule has no seek time by being based on Flash Memory technology.

2.3.3 Mount Time

The Mount Time for initializing and mounting DiskOnModule is different by depending on Operating System and testing Platform.

2.3.4 Data Transfer Time

- Sequential Read: 7 MB/sec
- Sequential Write: 5 MB/sec

※ Test Platform: GIGA 81945GME Intel:945+ICH7 3.0GHz DDR:400

Testing Software: HD Bench 3.4 Testing OS: Windows XP



The value is various bases on the testing platform.

2.3.5 Data Retention

- 10years without requiring power support

2.3.6 Wear-leveling

- Dynamic Wear-Leveling for same level of Write/Erase Cycle

2.3.7 Bad Block Management

- The Bad Blocks of Flash Memory will be replaced into new ones by controller.

2.4 Environmental Specifications

2.4.1 Temperature

- Operating Temperature: 0°C to +70°C, Non Operating Temperature: -40°C to +85°C (Industrial type)

2.4.2 Humidity

- Operating Humidity: 10% to 95%
- Non-Operating Humidity: 10% to 95% (with no condensation relative humidity)
-

2.4.3 Vibration

- Random Vibration (Operation) : Testing Specification

Frequency (Hz)	PSD (G2/Hz)	Acceleration (Grms)	Dwell Time (Min)
10	0.01	6Grms	30min per axis (X · Y · Z)
100	0.08		
500	0.08		

- Sine Vibration (Non-Operation) : Testing Specification

Testing Specification		
Frequency (Hz)	Acceleration (G)	Dwell Time (min)
10~500 Hz	15 G	30min per axis (X · Y · Z)

2.4.4 Bare Drop Testing

- Testing Conditions: 75cm height
- Testing Orientation: (Free fell) Front/Rear/Right/Left/Top/Bottom side
- Testing Result: Pass

2.4.5 Shock and Altitude
T. B. D.

2.5 Reliability Specifications

2.5.1 ECC/EDC (Error Correction Code/Error Detection Code)

- 2bytes data per 251bytes will be corrected.

2.5.2 Read and Write/Erase Cycle

- Read: No Limitation
- Write/Erase: 5,000,000 times
(Estimated on reference to Doc No.SM070001)

2.5.3 MTBF (Mean Time Between Failure)

- 2,000,000 hours
(Estimated on reference to Doc No.SM070002)

2.6 Compliance Specifications

- CE
- FCC

※ Note: Please contact your closest PQI's office for other certificate information.

3. Function

3.1 Switch Setting

3.1.1 Master/Slave Switch

- On case which the switch place “Master” side, then the DOM will be recognized as C: Drive in system and operate as main storage device.
- On case of placing in “Slave” side, the DOM will be recognized as slave disk and operate as slave storage device.

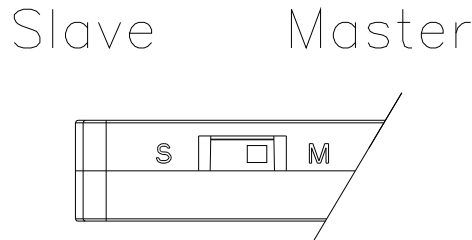

Figure 4: Master/Slave Function Switch

3.2 Pin Signal Assignment

- The signals assigned for ATA applications are described in Table 2

Table 2: ATA connector pin definitions

Signal name	Connector contact	Conductor		Connector contact	Signal name
RESET-	1	1	2	2	Ground
DD7	3	3	4	4	DD8
DD6	5	5	6	6	DD9
DD5	7	7	8	8	DD10
DD4	9	9	10	10	DD11
DD3	11	11	12	12	DD12
DD2	13	13	14	14	DD13
DD1	15	15	16	16	DD14
DD0	17	17	18	18	DD15
Ground	19	19	20	20	NC
DMARQ	21	21	22	22	Ground
DIOW-	23	23	24	24	Ground
DIOR-	25	25	26	26	Ground
IORDY	27	27	28	28	CSEL
DMACK-	29	29	30	30	Ground
INTRQ	31	31	32	32	Ground
DA1	33	33	34	34	PDIAG-
DA0	35	35	36	36	DA2
CS0-	37	37	38	38	CS1-
DASP-	39	39	40	40	Ground
Vcc	41	41	42	42	Vcc
Ground	43	43	44	44	reserved

※ Notes:

1. All pins are in a single row, with a 2.0 mm (0.0785”) pitch.
2. The comments on the mating sequence apply to the case of backplane blind mate connector only. In this case, the mating sequences are:
 - - the pre-charge power pints and the other ground pins.
 - - the signal pins and the rest of the power pins.

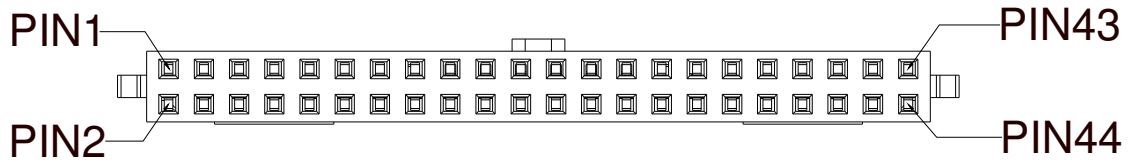

Figure 5: Signal Connector

3.3 Capacity Specifications

Table 3: Capacity Specifications

Capacity	Cylinder	Head	Sector	Total sectors
32MB	500	8	16	64000
64MB	500	8	32	128000
128MB	500	16	32	256000
256MB	1000	16	32	512000
512MB	1015	16	63	1023120
1024MB	2031	16	63	2047248
2048MB	4063	16	63	4095504
4096MB	8146	16	63	8211168

3.4 Absolute Maximum Ratings

Table 4: Absolute Maximum Rating

Item	Symbol	Parameter	MIN	MAX	Unit
1	VDD-VSS	DC Power Supply	-0.3	+5.5	V
2	VIN	Input Voltage	VSS-0.3	VDD+0.3	V
3	Ta	Operating Temperature	-0	+70	°C
4	Tst	Storage Temperature	-40	+85	°C

4. Ordering Information

Table 5: DiskOnModule Ordering Information

P/N	Capacity (Max)
DQ0032M-122R-2D-30	4GB

* 1 : 032:32MB, 064M:64MB, 128M: 128MB, 256M: 256MB, 512M:512MB, 010G:1GB, 020G:2GB, 040G:4GB

* 2 : R: Industrial type

* 3 : : Flash Density
D:32MB, E: 64MB, F:128MB, I:256MB, L:512MB, N:1GB, P:2GB